

ALIGNMENT

Pump and Driver Alignment

Alignment Subject: Pump and Driver Alignment

In the pump business alignment means that the centerline of the pump is aligned with the centerline of the driver. Although this alignment was always a consideration with packed pumps, it is critical with sealed pumps; especially if you are using rotating seal designs where the springs or bellows rotate with the shaft.

A little misalignment at the power end of the pump is a lot of misalignment at the wet end, and unfortunately that is where the seal is located in most pump applications.

Misalignment will cause many problems:

- It can cause rotating mechanical seals to move back and forth axially two times per revolution. The more the seals move the more opportunity for the lapped faces to open.
- Packing could support a misaligned shaft. A mechanical seal cannot.
- Misalignment will cause severe shaft or sleeve fretting if you use spring loaded Teflon® as a secondary seal in your mechanical seal design.
- The pump bearings can become overloaded.
- The misalignment could be severe enough to cause contact between stationary and rotating seal components.
- The wear rings can contact.
- The shaft can contact the restriction bushing often found at the end of the stuffing box.
- The shaft or sleeve can contact the stationery face of the mechanical seal.
- The shaft can contact the disaster bushing in an API (American Petroleum Institute) gland.
- The impeller could contact the volute or back plate.

Regardless of the alignment method you select, you must start with a pump and driver in good repair. A perfectly aligned piece of junk is still a piece of junk. You should also check the following:

- A straight shaft that has been dynamically balanced.
- Good wear rings with the proper clearance.
- The correct impeller to volute, or backplate clearance.
- The elimination of "soft foot".
- Eliminate all pipe strain.
- Good bearings installed on a shaft with the proper finish and tolerances.
- A good mechanical seal set at the proper face load. The closer the seal is to the pump bearings the better off you are going to be.

All pump to driver alignments consist of four parts:

- You must level the pump and driver. If the pump is aligned without being level, the oil level will be incorrect and you will develop bearing problems.
- You then take a series of radial and axial measurements to see where the pump is located in respect to its driver (motor).
- You make calculations to see how far the driver must be moved to align the centerline of the pump to the centerline of the driver. These calculations must consider that the pump and driver operating temperature will probably be very different than the ambient temperature when you are taking the readings.
- Most pump manufacturers should be able to supply you with the proper readings for a hot alignment. They are the only people that know how their unit expands and contracts with a change in temperature.

- You must now shim and move the driver to get the alignment. Most of the small pump designs are not equipped with "jack bolts" so this will be the most difficult part of the alignment procedure. You cannot move the pump because it is connected to the piping.

I see lots of pumps that have never been aligned properly. When you talk to the people that should be concerned, you get the following comments:

- Alignment is not important. I have been working with pumps for years and we never do it at this facility. And we do not do dynamic balancing of the rotating assembly either!
- There is no time to do an alignment. Production wants the unit back on line, and they will not allow me the time to do it properly.
- We purchase good couplings. The coupling manufacturer states that their coupling can take a reasonable amount of misalignment.

It turns out that there are at least three methods of getting a good pump to driver alignment, and a good coupling is not one of them. The coupling is used to transmit torque to the shaft and compensate for axial thermal growth, nothing else. You install a good coupling after you have made the pump to driver alignment, not instead of making the alignment.

Here are some acceptable methods:

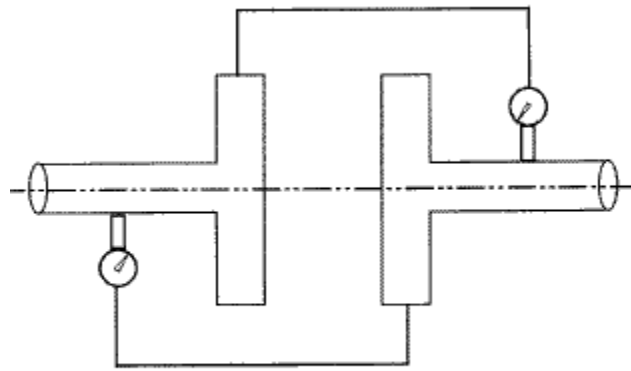

Reverse Dial Indicator

The reverse indicator method is an acceptable method, but it does take a great deal of time. There are plenty of schools that teach this method if you are interested in learning how to do it:

- Very accurate especially for small diameter flanges
- Not affected by axial float.
- Can be used with a flexible coupling in place.
- You have to rotate both shafts

The laser is the latest method. It is also the most popular. There are lots of people that can teach you to use the equipment, once you have made the purchase.

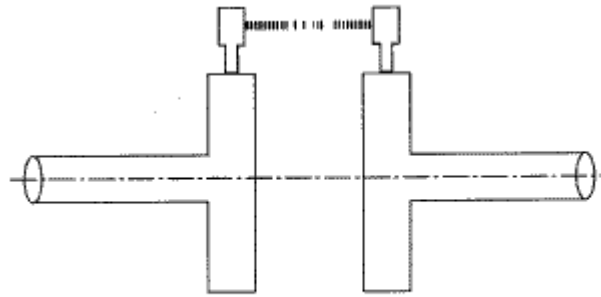

Laser Aligning

The "C or D" frame adapter is probably the easiest method of all and available from most quality pump manufacturers. It solves most of the problems with thermal expansion.

You use a machined, registered fit to insure the alignment.

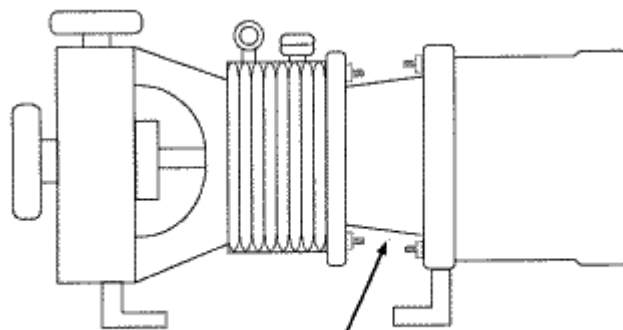

C or D Frame Adapter

The shaft to coupling spool method:

- The best method when there are big distances between the shaft ends.
- A simple method to use.
- Most people rotate both shafts

Face and rim method:

- Use this method if one of the shafts cannot be rotated.
- An excellent method for large shaft diameters (8 inches or 200mm or greater) or if the diameters are equal to, or greater than the span from the bracket location to the face and rim location where the readings are to be taken.
- Not too good a method if there is axial float from sleeve or journal bearings.

Given a choice I would select the C or D frame every time.

- The "C frame" is for inch sizes The "D frame" for metric sizes.
- Automotive people use the same concept to align an automobile transmission to the engine. They call the adapter a "bell housing".
- The concept was originally developed for the marine industry where it would be impossible to bolt the motor and pump to the deck of the ship, and then do an alignment. The hull flexes making any conventional alignment ineffective. The same logic applies to off shore drilling rigs.

- The adapter does a better job of equalizing the heat transfer between the pump and the driver. It does not all have to conduct through the shaft.
- The adapter is available for all quality end suction centrifugal pumps. Check with your supplier for the availability of one for your pump
- When given a choice, select a ductile rather than a cast adapter.
- Up to about thirty-horse power (22 KW) you hang the motor on the pump. Above thirty-horse power (22 KW) you hang the pump on the motor.
- The adapter solves the problem of "there is no time to do an alignment".
- If your motor does not have a "C or D" end bell, one can be installed when the motor is rewound. Some, but not all explosion proof motors are available with a C or D frame end bell. Check with your supplier.

If you do not have a C or D frame adapter you will be involved in the last three steps of the four-step procedure.

Once you have made all the measurements, put in the recommended compensation for thermal expansion, and figured out all the calculations for how much to move the driver and in which direction, then comes the fun part; moving the driver.

You can hit the motor with a big hammer, but small dimensions are hard to get with this method.

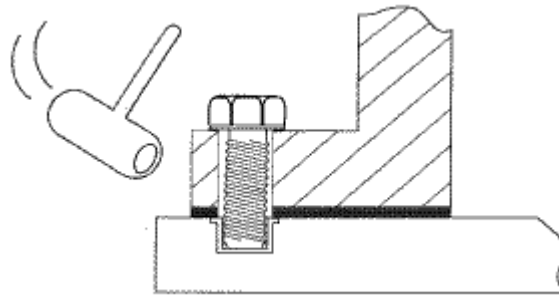

Some people use an adjusting wheel that attaches to shims. This will give you a very precise movement that is necessary for a proper alignment

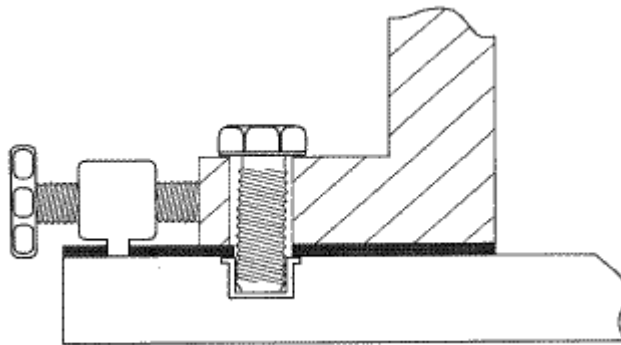

Another method is to use an adjusting wheel that slips over the motor hold down bolts. Many mechanics make their own tools and these units also work very well for precise motor movement.

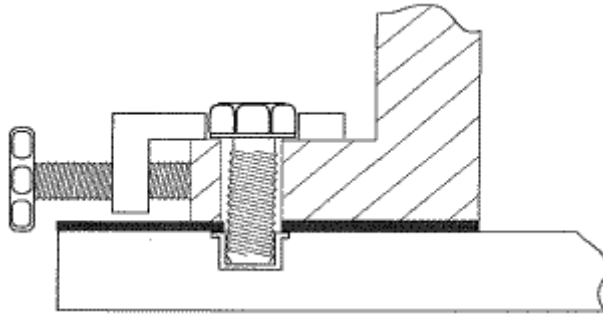

How concerned should you be about alignment? You do it on your automobile when you notice uneven tire wear or the car drifts to one side of the road when you loosen your grip on the wheel, and have no problem justifying the cost and time involved. It is the same logic you use towards the added cost and time spent balancing the tires and wheels of your car.

We do not always apply the same logic to our very expensive rotating equipment in the shop, but we should. A mechanical seal should run trouble free until the carbon sacrificial face has worn away. When we inspect the seals we remove from leaking pumps, we find that in more than 85% of the cases there is plenty of carbon face left on the seals. The seals are leaking prematurely and the seal movement caused by pump to motor misalignment is a major contributing factor.

LaBour Pump Company – 901 Ravenwood Drive, Selma, Alabama 36701

Ph: (317) 924-7384 - Fax: (317) 920-6605 - www.labourtaber.com

Document # - A Product of Peerless Pump Company Copyright © 2005 Peerless Pump Company

